

## TER Tapping system

### Features:

- For tapping on Machining Centers and CNC Milling Machine with or without rigid-tap function.

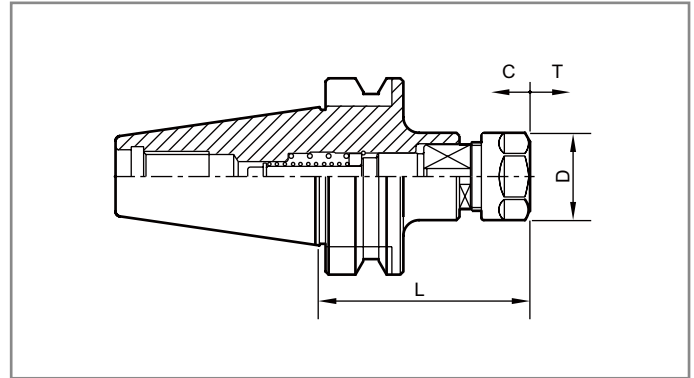

Taper Shank	Ordering Code	Type of Holder	Tapping Capacity	D	L	T	C
BT30	330290-302	BT30-TER16-75	M3-M10	28	75	8	4
	-402	-TER20-100	M4-M16	34	100		
BT40	340290-303	BT40-TER16-75	M3-M10	28	75	8	4
	-304	-TER16-100	M3-M12	28	100		
	-402	-TER20-80	M4-M16	34	80		
	-404	-TER20-100	M4-M16	34	100		
	-602	-TER32-100	M8-M27	50	100	10	
BT50	350290-302	BT50-TER16-100	M3-M12	28	100	8	4
	-304	-TER16-150	M3-M10	28	150		
	-402	-TER20-120	M4-M16	34	120		
	-404	-TER20-150	M4-M16	34	150	10	
	-602	-TER32-100	M8-M27	50	100		
	-604	-TER32-150	M8-M27	50	150		

## THLK Quick Change Tapping System

- With length compensation on compression and extension.
- Please refer to page 57, 58 for tapping adapters.

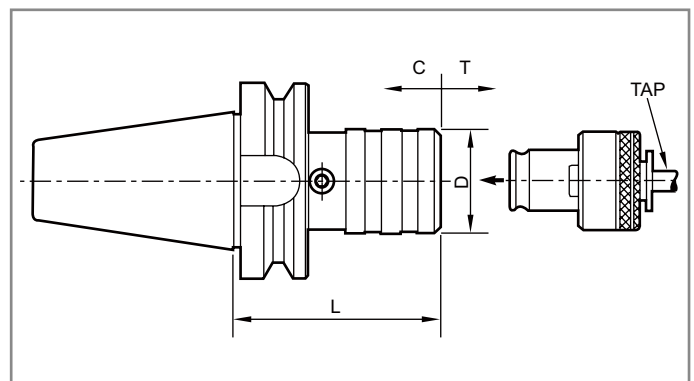

Taper Shank	Ordering Code	Type of Holder	Size of Tap Collet	Tapping Capacity	D	L	C	T
BT30	330710-102	BT30-THLK115	1	M3-M12	36	57	6	12
	-202	-THLK225	2	M8-M22	53	95	12.5	12.5
BT40	340710-102	BT40-THLK115	1	M3-M12	36	62	6	12
	-202	-THLK225	2	M8-M22	53	93.5	12.5	12.5
	-302	-THLK340	3	M16-38	78	164	20	20
BT50	350710-102	BT50-THLK115	1	M3-M12	36	71	6	12
	-202	-THLK225	2	M8-M22	53	102.5	12.5	12.5
	-302	-THLK340	3	M16-M38	78	142	20	20